

Essential weighing functions in a compact water & dust proof design



KEY FEATURES:



FX-iWP | WPN
External Calibration



RS-232C



VFD Display



Rechargeable battery



GLP Compliant



Underhook



Legal for Trade
(N version)



IP65

Advanced Sensor Technology

- C-SHS Patented weighing technology

Robust & Durable

- Patented weighing technology “Compact Super Hybrid Sensor”(C-SHS) makes it compact, fast, and precise with 1 second stabilization
- Feel confident with overload protection, durable full metal construction, & easy to clean stainless steel weigh pan
- WP versions IP65 ratings permit no ingress of dust (level 6) and withstand water jetting from any direction (level 5).
- Take tough draft and vibration conditions head-on with our adjustable response filters and shock absorber functions.

Versatile Weighing

- Need compliance? We’ve got you covered as it meets GLP/ GMP/GCP/ISO requirements
- A wide range of modes to meet your applications/workflow needs: Counting, Percent, Animal, Statical Calculation & Comparator, Auto Power ON/OFF
- Multiple weighing units: g, oz, lb, lb-oz, ozt, ct, mom, dwt, grain

Quick and Easy Measurements

- Easy-to-use “One-touch” Cal button
- Fast and precise measurements within a second
- Large, bright vacuum florescent display

Flexible Communications

- RS-232C Interface (standard) allows for Bi-directional communications with peripheral devices
- Quick USB Interface (FXi-02) an easy-to-use optional USB interface requires no driver or software installation for transfer of weighing data to a PC.
- LAN-Ethernet Interface (FXi-08) with WinCT-Plus Software can send commands for controlling and acquiring data from multiple balances

Specifications

		FX-120iWP / FX-120iWPN	FX-200iWP / FX-200iWPN	FX-300iWP / FX-300iWPN	FX-1200iWP / FX-1200iWPN	FX-2000iWP / FX-2000iWPN	FX-3000iWP / FX-3000iWPN
Capacity x Resolution (g)		122 x 0.001	220 x 0.001	320 x 0.001	1220 x 0.01	2200 x 0.01	3200 x 0.01
Counting Mode	Min. Unit Mass	0.001g			0.01g		
	# of Samples	5, 10, 25, 50 or 100 pieces					
Percent Mode	Min. 100% Ref. Mass	0.100g			1.00g		
	Min. 100% Display	0.01%, 0.1%, 1% (depends on the reference mass stored)					
Repeatability (Std. Deviation)		0.001g			0.01g		
Linearity		±0.002g			±0.02g		
Stabilization Time (in FAST conditions)		Approx. 1 second					
Sensitivity Drift (10°C to 30°C)		±2ppm / °C					
Operating Temp		5°C to 40°C (41°F to 104°F), 85% RH or less (No condensation)					
Display Type		Vacuum Fluorescent Display (VFD)					
Display Refresh Rate		5 times / second, 10 times / second or 20 times / second					
Std. Serial Interface		RS-232C Interface					
Weighing Pan		130mm			150mm		
External Calibration		100g 50g	200g 100g	300g 200g 100g	1000g 500g	2000g 1000g	3000g 2000g 1000g
AC Adaptor		Confirm that the adaptor type is correct for the local voltage and power receptacle					
Power Consumption		Approx. 11VA (supplied to the AC Adaptor)					
External Dimensions		193 (W) x 262.5 (D) x 84.5 (H) mm					
Net Weight		Approx. 2.5kg					

Dimensions (mm)

FX-120iWP / 200iWP / 300iWP

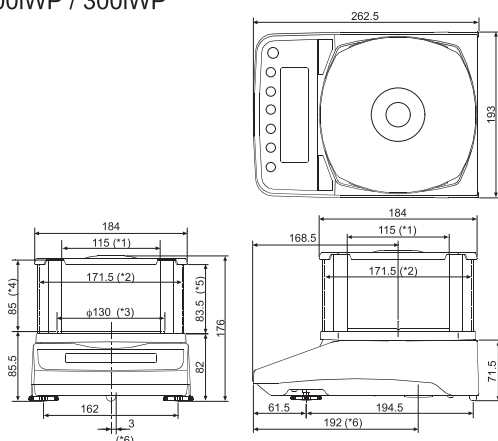

FX-1200iWP / 2000iWP / 3000iWP

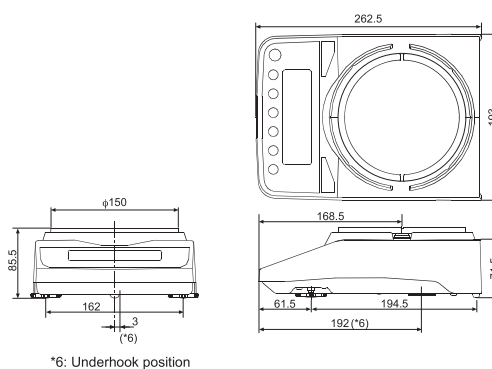

1756 Automation Parkway
San Jose, CA 95131
888-726-5931 or 408-263-5333
andweighing.com

